

**RESOLUTION NO. 2017-15**

**A RESOLUTION AMENDING RESOLUTION 2016-53 ADOPTED JULY 12, 2016 AUTHORIZING CHANGE ORDER NO. 1 FOR ROPPER CONSTRUCTION INCORPORATED FOR ADDITIONAL LABOR AND MATERIALS RELATED TO THE, MAIN STREET STREETScape PROJECT, ODOT ERI-PID 93574, IN THE INCREASED AMOUNT OF SEVEN THOUSAND FOUR HUNDRED THIRTY AND 00/100 DOLLARS (\$7,430.00)**

**BE IT RESOLVED BY THE COUNCIL OF THE CITY OF HURON, OHIO:**

**SECTION 1.** That the Council of the City of Huron authorizes and directs the City Manager to accept Change Order No. 1 from Ropper Construction Inc., pertaining to the ODOT ERI-PID 93574 Main Street Streetscape Project in the increased amount of Seven Thousand Four Hundred Thirty and 00/100 Dollars (\$7,430.00); Change Order No. 1 shall be in substantially the form of Exhibit "A" attached hereto and made a part hereof.

**SECTION 2.** That this Council hereby finds and determines that all formal actions relative to the adoption of this Resolution were taken in an open meeting of this Council and that all deliberations of this Council and of its Committees, if any, which resulted in formal action, were taken in meetings open to the public in full compliance with applicable legal requirements, including O.R.C. §121.22.

**SECTION 3.** That this Resolution shall be in full force and effect from and immediately after its adoption.

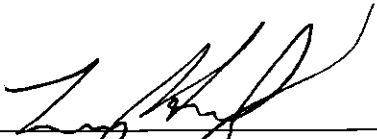
  
\_\_\_\_\_  
Trey Hardy, Vice Mayor

ATTEST:   
Clerk of Council

ADOPTED:           MAR 14 2017

CHANGE ORDERNUMBER: 01

OWNER: City of Huron  
PROJECT: ERI – Huron – Main St. Streetscape Improvements  
PID No. 93574  
QCI PROJECT No: 269-2016-182  
DATE: March 6, 2017  
CONTRACTOR: Ropper Construction, Inc.  
CONTRACT FOR: City of Huron  
ORIGINAL CONTRACT COMPLETION TIME (CALENDAR DAYS) / DATE: OCTOBER 31, 2017  
ORIGINAL CONTRACT AMOUNT: \$692,449.30  
CHANGE ORDER # ( ) \_\_\_\_\_  
CHANGE ORDER # ( ) \_\_\_\_\_  
CHANGE ORDER # ( ) \_\_\_\_\_  
CONTRACT AMOUNT PRIOR TO THIS CHANGE ORDER \$692,449.30

THIS CHANGE ORDER, WHICH REPRESENTS A REVISION TO THE ABOVE "APPROVED" CONTRACT DOCUMENTS, CONSTITUTES AUTHORITY TO PROCEED WITH SAID REVISION, AS DESCRIBED BELOW:

NATURE AND JUSTIFICATION OF CHANGES:

## EWO-11

- A.) Furnish and install 2 ea. 150kVa transformer vaults @ \$2,815.00 ea. = \$5,630.00  
B.) Furnish and install 8 ea. 18" Quazite pullboxes, 725.06 @ \$675.00 ea. = \$5,400.00  
C.) Adjust Pay Item No. 48 *Pullbox, 725.08* from the plan qty of 8 ea. to the revised qty of 2 ea. The net adjustment is -6 ea. @ \$600.00 ea. = (\$3,600.00)

These items represent the work indicated on the Project Plan Drawings. The types and quantities were verified through the coordinated review between the City and First Energy. This Change Order is necessary to address the payment for these items. As noted above, the items were identified in the Project Plan details. However, the final quantities and work items were not included in the Project General Summary or the Project Bid Price.

Total Amount of Change Order = \$7,430.00

These modifications will be paid 80% - ODOT/ 20% - City

---

---

THIS CHANGE RESULTS IN THE FOLLOWING ADJUSTMENTS OF THE CONTRACT PRICE AND/OR CONTRACT COMPLETION TIME:

Contract price prior to this Change Order:	<u>\$692,449.30</u>
Net cost change (decrease) resulting from this Change Order:	<u>\$7,430.00</u>
Current contract price including this Change Order:	<u>\$699,879.30</u>
Contract completion time/date prior to this Change Order:	10/31/2017 _____
Net In/Decrease resulting from this Change Order:	<u>0 days</u> calendar/ days
Current contract time/date including this Change Order:	10/31/2017 _____

---

THE TERMS OF THIS CHANGE ORDER SHALL NOT AFFECT ANY OF THE TERMS OF THE CONTRACT, EXCEPT AS EXPRESSLY STATED HEREIN. FURTHER, THE CONTRACTOR AGREES THAT THE CONSIDERATION FOR THE CHANGE ORDER AS CONTAINED HEREIN IS THE FULL AMOUNT THE CONTRACTOR SHALL BE ENTITLED AND THAT NO ADDITIONAL TIME IS NECESSARY TO COMPLETE THIS CONTRACT.

The above changes are approved:

CITY OF HURON:

By: \_\_\_\_\_ DATE: \_\_\_\_\_

The above changes are accepted:

ROPPER CONSTRUCTION, INC.

By: \_\_\_\_\_ Date: \_\_\_\_\_  
Chris Ropper

Above changes recommended by:

QUALITY CONTROL INSPECTION, INC.

By: \_\_\_\_\_ Date: \_\_\_\_\_  
EDMUND CHRZANOWSKI, P.E., CONSTRUCTION PROJECT ENGINEER

C:\WORK\QCI\SHARED\HURON, CITY OF\MAIN ST. PID No. 93574\CHANGE ORDERS\CO-01\CO-01.DOC

QUAZITE 18" PULLBOXES

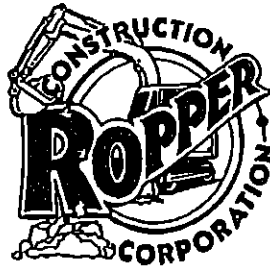

**Heavy Highway Construction**

P.O. Box 561 • Norwalk, Ohio 44857 • Phone & Fax (419) 668-3604

An equal opportunity employer

23-Feb-17

To: Doug Green  
OHM Advisors  
Doug.Green@ohm-advisors.com  
330-657-2145

From: Reuben Kent  
Ropper Construction Corporation

Page 1 of 1

RE: Quote - Quazite Pull Boxes PG118BS18 & Cover PG118HA0018

Main Street Streetscape PID 83574

Ref	Description / Location	Quantity	Unit	Unit Price	Amount
625	725.051 Quazite Pull Boxes PG118BS18 & Cover PG118HA0018	8	Ea	\$ 676.00	\$ 5,400.00
	Total				\$ 5,400.00

Notes:

If there are any questions or if additional information is needed, please do not hesitate to call us at (419)668-3604 or (419)708-3607.

Proposed By: Reuben Kent Date: 2-23-17

Accepted By: \_\_\_\_\_ Date: \_\_\_\_\_

PEN OSDOS HISTORICAL DATA FOR ITEM 725.06 18", THE AVERAGE AWARD PRICE IS \$ 676.98. THEREFORE, THIS PROPOSED PRICE IS ACCEPTABLE.

El Cyl.  
ACI  
03/06/17

# Quotation



**ELECTRIC INCORPORATED**  
 1513 Sycamore Line  
 Sandusky, Ohio 44870

**SANDUSKY (419) 625-4915**  
 FAX (419) 625-9438  
**NORTH RIDGEVILLE (440) 327-8000**  
 FAX (440) 327-3219  
**AKRON (330) 733-7400**  
 FAX (330) 733-6209  
**BOWLING GREEN (419) 354-3230**  
 FAX (419) 353-6615

## ELECTRICAL WHOLESALE - INDUSTRIAL AUTOMATION

[www.sanduskyelectric.com](http://www.sanduskyelectric.com)

TO: *Roppel Const Inc.*  
 ATTN: *REUBEN - CHRIS*  
 Email:

DATE	2-20-17	TERMS	NET 30	QUOTE#	Huxol Main Dr Upgrade
JOB	Origin	DELIV/TIME			

Thank you for your inquiry. We are pleased to quote as follows:

#	QTY	UNIT	DESCRIPTION	UNIT PRICE
1	8		QUAZITE PG 1118 BA18 BOX 15,000/22,500 RATING	152.00 EA
2	8		QUAZITE PG 1118 HA0018 COVER 15,000/22,500 RATING ELECTRIC LOGO	189.50 EA
3			(FACTORY STOCK IN TENN.)	
4			PLEASE RESUBMIT FOR APPROVAL	
5				
6				
7				
8				
9				
10				
11				
12				
13				
14				
15				

It has been a pleasure to prepare this quotation. May we process your order soon?

Sincerely,  
**Jeff Lange**  
*Senior Outside Sales Specialist*  
 Sandusky Electric, Inc.  
 Ph: 419-625-4915  
 Cell: 419-656-4227  
 Fx: 419-625-9438  
[jlange@sanduskyelectric.com](mailto:jlange@sanduskyelectric.com)

**\*\*This quote expires 30 days from the above date and is subject to change without prior notice.\*\***



# Dimensions / Data

## 11" x 18" PG Style Polymer Concrete (Stackable) Assembly

Hex Head Bolts are Standard

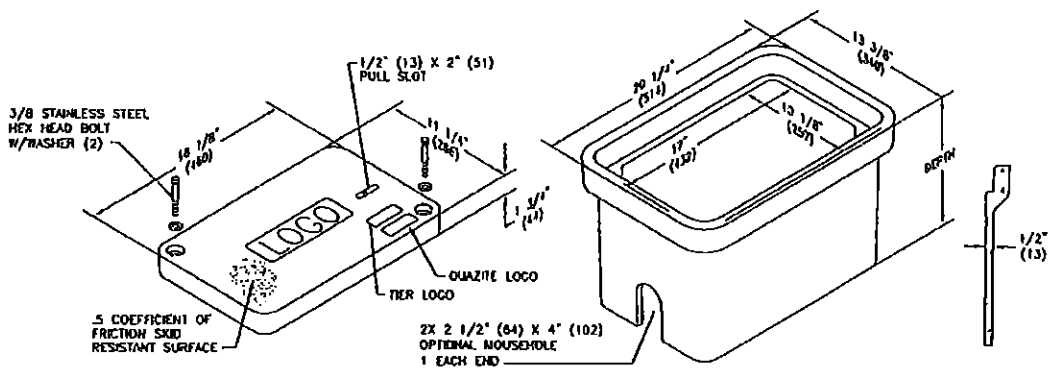

QUAZITE

### Covers

DESCRIPTION	TIER	DESIGN / TEST LOAD #	WEIGHT #	PALLET QTY	PART NO.
W/ 2 Bolts	8	8,000 / 12,000	27	40	PG1118CA00**
W/ 7 Bolts	15	15,000 / 22,500	27	40	PG1118HA00**
No Bolts	8	8,000 / 12,000	27	40	PG1118WA00**
W/ 2 Bolts	22	22,500 / 33,750	27	40	PG1118HA00**

To order gasketed covers, replace the letter "A" with the letter "G".  
 Replace "\*\*" with a logo code found on page 60. See page 65 for meter and touch/radio read cover options.  
 NOTE: Gasketed covers and bolt grommets must be used with a gasketed box. Gaskets reduce the inflow of fluids but do not make the enclosure water tight.

### Boxes

DESCRIPTION	DEPTH	TIER	DESIGN / TEST LOAD #	WEIGHT #	PALLET QTY	PART NO.
Standard Open Bottom	12"	22	22,500 / 33,750	40	30	PG1118BA12
	18"	22	22,500 / 33,750	53	24	PG1118BA18
Solid Bottom	12 1/2"	22	22,500 / 33,750	43	30	PG1118DA12
	18 1/2"	22	22,500 / 33,750	60	24	PG1118DA18
Footed Box	12 1/2"	22	22,500 / 33,750	41	30	PG1118JA12
	18 1/2"	22	22,500 / 33,750	55	24	PG1118JA18

To order boxes with 2 standard mouseholes, replace the letter "A" with the letter "B".  
 To order gasketed boxes, replace the letter "A" with the letter "G".  
 NOTE: Gasketed covers and bolt grommets must be used with a gasketed box. Gaskets reduce the inflow of fluids but do not make the enclosure water tight.





Most commonly used cover logos are shown below.  
 Custom Logos are available. Contact your Quazite/Hubbell Representative.

## QUAZITE® COVER OPTIONS

### POLYMER CONCRETE LOGO CODES

### DESCRIPTION

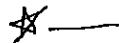

09	BLANK
10	CATV
12	COMMUNICATIONS
14	CONTROLS
17	ELECTRIC
21	FIBER OPTICS
22	FIRE ALARM
23	GAS
24	GROUND
26	HIGH VOLTAGE
29	LIGHTING
36	SECURITY
38	SIGNAL
40	STATE TRAFFIC SIGNAL
41	STREET LIGHTING
42	TELECOM
43	TELEPHONE
44	TRAFFIC
45	TRAFFIC CONTROL
46	TRAFFIC SIGNAL
43	TV
50	WATER
57	EMERGENCY
65	ILLUMINATION
81	DANGER HIGH VOLTAGE
84	POWER
92	TELECOMMUNICATIONS
3A	DOT
68	INSTRUMENTATION
ZA	IRRIGATION
K91	RECLAIMED WATER
KH1	FIBEROPTIC

QUAZITE



TRANSFORMER VAULTS

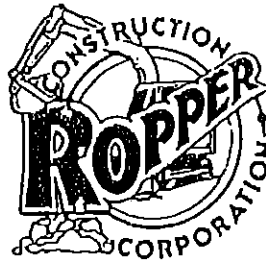

Heavy Highway Construction

PO Box 561 • Norwalk, Ohio 44857 • Phone & Fax (419) 668-3604

An equal opportunity employer

23-Feb-17

To: Doug Green  
OHM Advisors  
Doug.Green@ohm-advisors.com  
330-657-2145

From: Reuben Kent  
Ropper Construction Corporation

RE: Quote - Pre-Cast Pull Boxes and Transformer Vaults

Page 1 of 1

Main Street Streetscape PID 93574

Part of contract

Ref	Description / Location	Quantity	Unit	Unit Price	Amount
Spec	Furnish and Install 18" non traffic bearing pull box with frame and cover	2	Ea	\$ 600.00	\$ 1,200.00
Spec	Furnish and Install 150 KVA Transformer Vault per drawing E-0005-02	2	Ea	\$ 3,300.00	\$ 6,600.00
Total					\$ 7,800.00

Notes:

SEE ATTACHED ANALYSIS

2 ea @ 2,815 = \$5,630.00

If there are any questions or if additional information is needed, please do not hesitate to call us at (419)668-3604 or (419)706-3607.

Proposed By: Reuben Kent

Date: 2-23-17

Accepted By: \_\_\_\_\_

Date: \_\_\_\_\_



ERI-Huron Main St. Streetscape Improvements  
 PID No. 93574  
 EWO-11 Furnish & Install 150k Vaults - 2 ea.

LABOR

	BHR	Hours	Total	Fringe	
<u>Pick up &amp; delivery of vault</u>					
Laborer	\$29.65	4	\$118.60	\$10.45	\$11.80
			\$0.00		\$0.00
<u>Installation</u>					
Foreman	\$38.58	4	\$146.32	\$14.50	\$58.00
Operator	\$35.58	4	\$142.32	\$14.50	\$58.00
Laborers	\$29.65	8	\$237.20	\$10.45	\$83.60
			\$0.00		\$0.00
			\$0.00		\$0.00
			\$0.00		\$0.00
			\$0.00		\$0.00
			\$0.00		\$0.00
			\$0.00		\$0.00
			\$0.00		\$0.00
			\$0.00		\$0.00
			\$0.00		\$0.00
			\$0.00		\$0.00
			\$0.00		\$0.00
			\$0.00		\$0.00
			\$644.44	\$241.40	\$885.84

Labor	38%	\$644.44	\$889.33
Fringe	38%	\$241.40	\$333.13
Tax	22%	\$644.44	\$141.78
Equipment		\$929.80	\$929.80
Rental Equip	15%	\$0.00	\$0.00
Subcontractor	8%	\$0.00	\$0.00
Material	15%	\$2,900.00	\$3,335.00
Miscellaneous		\$0.00	\$0.00
			\$5,628.04

EQUIPMENT

	Rate		Oper Cost		
<u>Pick up &amp; delivery of vault</u>					
Dump truck, single axle	\$9.52	4	\$38.08	\$32.15	\$128.60
15' trailer	\$10.00	4	\$40.00	\$2.00	\$8.00
			\$0.00		\$0.00
<u>Installation</u>					
Excavator - Kobelco					
135RLC	\$34.74	4	\$138.96	\$29.65	\$118.60
Dump Truck, quad	\$21.30	4	\$85.20	\$41.60	\$166.40
Foreman's truck	\$6.42	4	\$25.68	\$12.95	\$51.80
Rubber-tired loader	\$15.62	4	\$62.48	\$16.50	\$86.00
			\$0.00		\$0.00
			\$0.00		\$0.00
			\$390.40	\$539.40	\$929.80

Unit price = \$2,814.52

RENTAL EQUIPMENT

\$0.00

SUBCONTRACTOR

\$0.00

\$0.00

MATERIAL

NCI precast vaults	1,450.00	2		\$2,900.00
Aggregate - use pay item 40				\$0.00

\$2,900.00

MISCELLANEOUS

\$0.00

## Ed Chrzanowski

---

From: ropper1@roadrunner.com  
Sent: Thursday, March 02, 2017 8:04 AM  
To: Ed Chrzanowski; Doug.Green@ohm-advisors.com; caopper1@icloud.com  
Subject: Re: FW: FW: Huron - Main Street PID 93574 - Pre-Cast Pull Boxes and Vault Quote

Ed,

We will agree the \$2815.00 per vault. Let me know if anything else is needed. Please add Chris Opper's new email address as [caopper1@icloud.com](mailto:caopper1@icloud.com).

Thanks,  
Reuben

---- Ed Chrzanowski <[echrzanowski@qcigroup.com](mailto:echrzanowski@qcigroup.com)> wrote:

> Reuben,

>

> I have reviewed your proposal for furnishing the transformer vaults. Your breakdown, as it is identified in your attached proposal, will not be accepted by ODOT as is. At the Preconstruction Conference, we noted that all changes are to be addressed in accordance with ODOT CMS Section 109.05. Based on the information that you gave, I attempted to present your proposal as per 109.05. I am attaching that analysis for your info. Your proposal is \$3,300.00 each. Using the ODOT 109.05 format, I came up with a unit price of \$2,815.00 ea.

>

> ODOT requires that the equipment costs are based on the blue book rental rates. I am including the rates that I was able to identify. I had to make some assumptions on the equipment based on what you have had on site previously. I used the labor rates that are listed on your certified payroll reports. For your foreman, I used the Operator's rate + \$1.00/ hr, since your foreman is not identified on your certified payroll reports.

>

> Aggregate will be paid for using the bid unit price for embankment. Your inclusion of an administrative fee of \$40 and overhead and profit of \$500 are not acceptable.

>

> Please review this information & let me know what, if any, changes should be made to the 109.05 analysis in order to come up with a unit price that is fair to the City & Ropper. I am including the spreadsheet as well as a template for you.

>

> Call me to discuss any questions that you have.

>

> Thank you,

>

> Ed Chrzanowski, P.E.

> Construction Project Engineer/ Contract Administrator Quality Control

> Inspection, Inc.

> 40 Tarbell Avenue

> Bedford, OH 44146

> (o) 440-359-1900

> (c) 440-241-3053

> [echrzanowski@qcigroup.com](mailto:echrzanowski@qcigroup.com)

>

> -----Original Message-----

> From: [ropper1@roadrunner.com](mailto:ropper1@roadrunner.com) [mailto:[ropper1@roadrunner.com](mailto:ropper1@roadrunner.com)]

> Sent: Tuesday, February 28, 2017 8:15 AM

> To: Ed Chrzanowski; [chestnutweber@hotmail.com](mailto:chestnutweber@hotmail.com); [caopper1@icloud.com](mailto:caopper1@icloud.com)

> Subject: Re: FW: Huron - Main Street PID 93574 - Pre-Cast Pull Boxes  
> and Vault Quote

>  
> Ed,  
> Attached is the breakdown for the vaults.  
>  
> -Reuben  
> ----- Ed Chrzanowski <[echrzanowski@qcigroup.com](mailto:echrzanowski@qcigroup.com)> wrote:  
>> Reuben,  
>>  
>> I need a more detailed justification for the cost for the vaults. Can you identify your labor & equipment in terms of amount of time, your crew size and the equipment used?  
>>  
>> Ed Chrzanowski, P.E.  
>> Construction Project Engineer/ Contract Administrator Quality  
>> Control Inspection, Inc.  
>> 40 Tarbell Avenue  
>> Bedford, OH 44146  
>> (o) 440-359-1900  
>> (c) 440-241-3053  
>> [echrzanowski@qcigroup.com](mailto:echrzanowski@qcigroup.com)  
>>  
>>  
>> -----Original Message-----  
>> From: [ropper1@roadrunner.com](mailto:ropper1@roadrunner.com) [<mailto:ropper1@roadrunner.com>]  
>> Sent: Thursday, February 23, 2017 5:30 AM  
>> To: [Doug.Green@ohm-advisors.com](mailto:Doug.Green@ohm-advisors.com); [caopper1@icloud.com](mailto:caopper1@icloud.com);  
>> [chestnutweber@hotmail.com](mailto:chestnutweber@hotmail.com); Ed Chrzanowski  
>> Subject: Huron - Maln Street PID 93574 - Pre-Cast Pull Boxes and  
>> Vault Quote  
>>  
>> Doug,  
>>  
>> Please find the attached quote for the concrete pull boxes and vault.  
>>  
>> Respectfully,  
>> Reuben Kent  
>> Ropper Construction, Inc.



Norwalk Concrete Industries

QUOTATION # 16-4851R2

DATE: 02-16-17

80 Commerce Drive P. O. Box 563
Norwalk, Ohio 44857
800.733.3624 Toll Free
419.668.8167 Phone
419.663.0627 Fax
www.nciprecast.com

TO:
ROPPER CONSTRUCTION CORP.
ATTN: REUBEN KENT
EMAIL: ropper1@roadrunner.com
PHONE: (419)668-3604
CELL: (419)668-5854
FAX: (419)668-3604

BID DATE:
JOB NAME: HURON MAIN STREET PID 93574
LOCATION: HURON
COUNTY: ERIE
OWNER:

Table with 4 columns: QTY, REF., DESCRIPTION, UNIT PRICE. Row 1: 2, 24" HL30.11 Non Traffic Bearing Precast Concrete Pullbox with frame and Cover Lettered as Required, \$ 230.00/ea. Row 2: 2, 150 KVA Transformer Vault Per Drawing E-0005-02, \$1,450.00/ea. Both rows include 'CUSTOMER PICK-UP'.

NCI is designated as a qualified HUBZone Small Business Concern (SBC)

PRICES ARE BASED ON QUANTITIES QUOTED. WE RESERVE THE RIGHT TO ADJUST PRICING SHOULD ORDER QUANTITIES DIFFER FROM THOSE QUOTED.

We Propose hereby to furnish material and labor--complete in accordance with the above specification.

Payment to be made as follows: NET 30 DAYS. NO TAXES INCLUDED. ALL PRICES ARE QUOTED/BID AS CASH PRICES ONLY. IF MANAGEMENT AGREES TO ACCEPT CREDIT CARDS FOR ANY PURCHASE THERE WILL BE A 3% CHARGE ADDED TO THE TOTAL OF THE PURCHASE.

All material is guaranteed to be as specified. All work to be completed in a professional manner according to standard practices. Any alterations or deviation from above specifications involving extra cost will be executed only upon written orders, and will become an extra charge over and above the estimate. All agreements contingent upon strikes, accidents or delays beyond our control. Owner to carry fire, tornado and other necessary insurance. Our workers are fully covered by Worker's Compensation Insurance.

Note: This proposal may be withdrawn by us if not accepted within 30 days.

Authorized Signature

Robert J. Smithson Email: rsmithson@nciprecast.com

Acceptance of Proposal--The above prices, specifications and conditions are satisfactory and are hereby accepted. You are authorized to do the work as specified. Payment will be made as outlined above.

Signature

Date of Acceptance